

## *8-Channel PCM\PPM Radio Control System* **Introduction Manual**

- Thank you for purchasing our 'Xinyi' R/C system.
- Before using, read this manual carefully.

Guangzhou Electronic Co., Ltd

---









◎ 2.4G    ● PCM    ◎ PPM

DIGITAL PROPORTIONAL R/C SYSTEM **N-8C R/C**



## COMMENTS

-  **Antenna**  
When turning on the transmitter, please make sure the transmitter antenna is completely extended. Turn on the transmitter before turning on the receiver, while turn off the receiver before turning off the transmitter. Stop operation of your transmitter when the power is lower than 8.6V.
-  **LCD**  
Shows the function of transmitter Handling of operation. It is frangible, do avoid hard press and crash.
-  **Control Stick**  
The stick length and the tension can be adjusted as described in control stick length&tension adjustment .
-  **Transmitter Power Switch**  
Push the switch in the arrow direction to turn on the transmitter.
-  **Handle.**  
It is for carrying the transmitter and assistant placement.
-  **Charger Jack(Battery)**  
It is used for charging NiCD and NiHm battery (AA size) for transmitter and receiver simultaneously or separately. Overcharging may cause burns, fire, injury, blindness, etc. For more details, Please refer to the Charger Introduction Manual for more details.

### Technology Data

	8-Ch RC	8-Ch RC	8-Ch RC
Type:	N-8C	N-8C	N-8C
Specification:	PCM	2.4G	PPM
Code format:	PCM/FM	PCM	PPM/FM
Channels:	8	8	8
Frequency:	35/36/40/41/72M (One type of them)	2.4G	35/36/40/41/72M (One type of them)
DC:	9.6V, ≤250mA	9.6V, ≤200mA	9.6V, ≤250mA
Measurement:	252*220*130mm (packing measurement)	320*240*120mm (Packing measurement)	252*220*130mm (packing measurement)
Net weight:	885g	950g	885g

## Table of Contents

Caution .....	1
1.1 N-8C Transmitter Chart .....	2
2.1 Menu .....	3
2.2 Function List .....	3
2.3 D/R .....	4
2.4 Rev. SW .....	4
2.5 Sub Trim .....	5
2.6 Trvl ADJ. ....	5
2.7 Hel-Plan Sel.....	6
2.8 Swash Mix .....	6
2.9 Stick Mode .....	7
2.10 Thro Curv .....	7
2.11 Pit. Curv .....	8
2.12 Models .....	8
2.13 Clear .....	9
2.14 Gyro Sens .....	9
2.15 Idle Thro .....	10
2.16 Idle Pith .....	10
2.17 SET CHANNEL (Only for 2.4G RC).....	11
2.18 STICK ADJ .....	11
2.19 THRO HOLD .....	11
3.1 Upright Operation of Left Stick and Movement of Elevator .....	12
3.2 Level Operation of Left Stick and Movement of Rudder .....	13
3.3 Upright Operation of Right Stick and Movement of Throttle .....	13
3.4 Level Operation of Right Stick and Movement of Aileron .....	14
4.1 Back of Transmitter .....	15
4.2 Trainer Function .....	15
5.1 Control Stick Length&Tension Adjustment .....	16
5.2 Loading Batteries .....	17
<b>6.1 Three-servo Connection Diagram .....</b>	<b>18</b>
<b>6.2 Two-servo Connection Diagram .....</b>	<b>19</b>
<b>6.3 Four-servo Connection Diagram .....</b>	<b>20</b>
<b>6.4 Airplane Connection Diagram .....</b>	<b>21</b>
2.4G Radio Data Transmission.....	22
COMMENTS .....	23
Technology Data .....	23

## 6.4 Airplane Connection Diagram

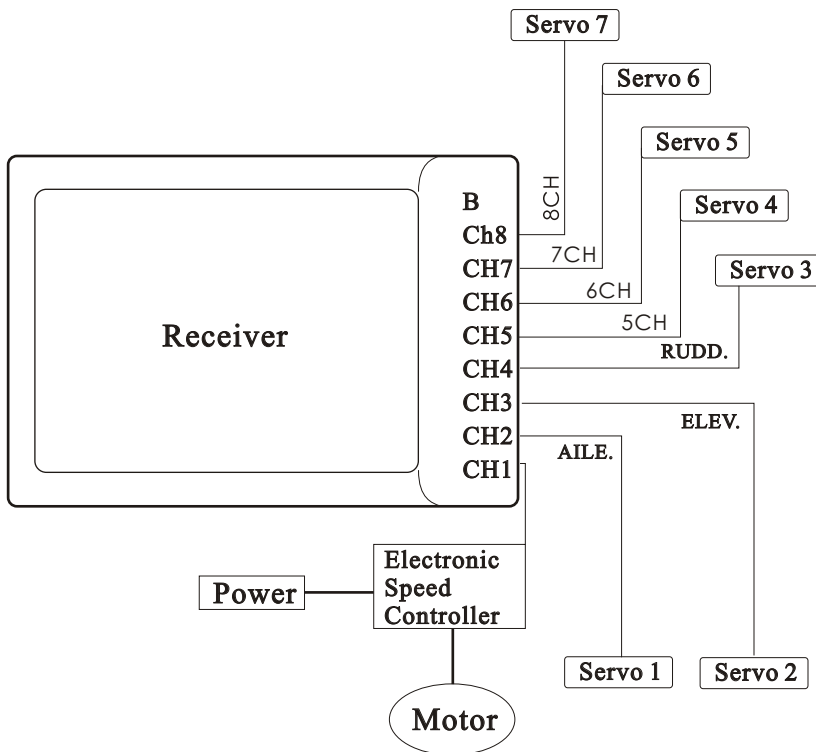
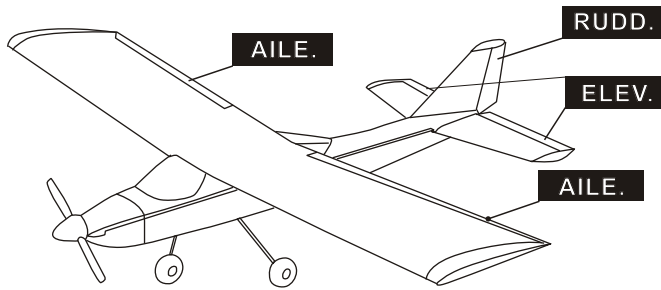

## 1.1 N-8C Transmitter Chart

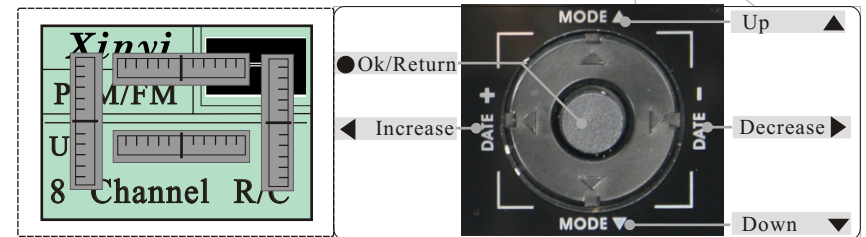
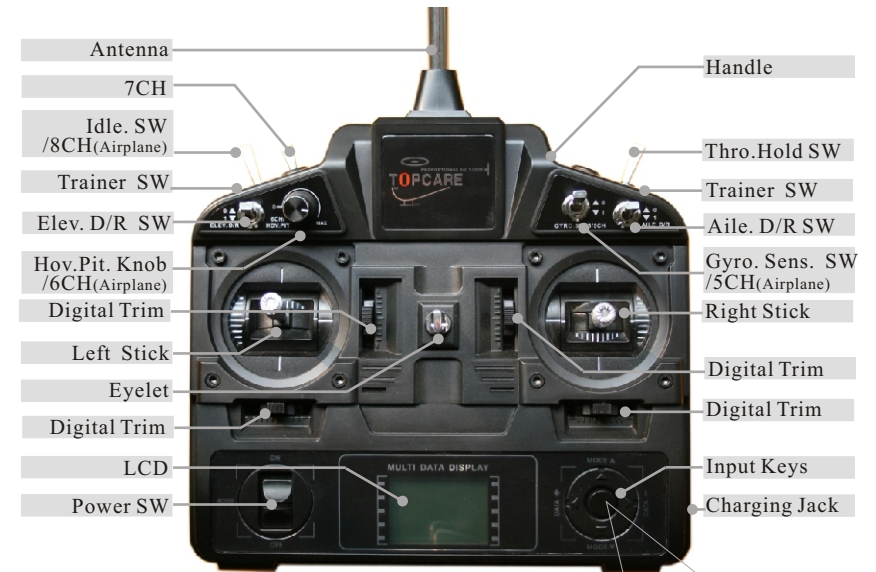

**Digital Trim Chart**

**Menu Func. Chart**

- Press "OK/Return" to enter the main menu. ("OK/Return" here in after referred to as "●")
- Press "Up" and "Down" for selecting functions in the list; press "●" to enter the selected function; press "●" to return to the previous menu. ("Up" here in after referred to as "▲"; "Down" here in after referred to as "▼")
- Press "Increase" and "Decrease" to change input data. ("Increase" here in after referred to as "◀"; "Decrease" here in after referred to as "▶")

## 6.2 Two-servo Connection Diagram

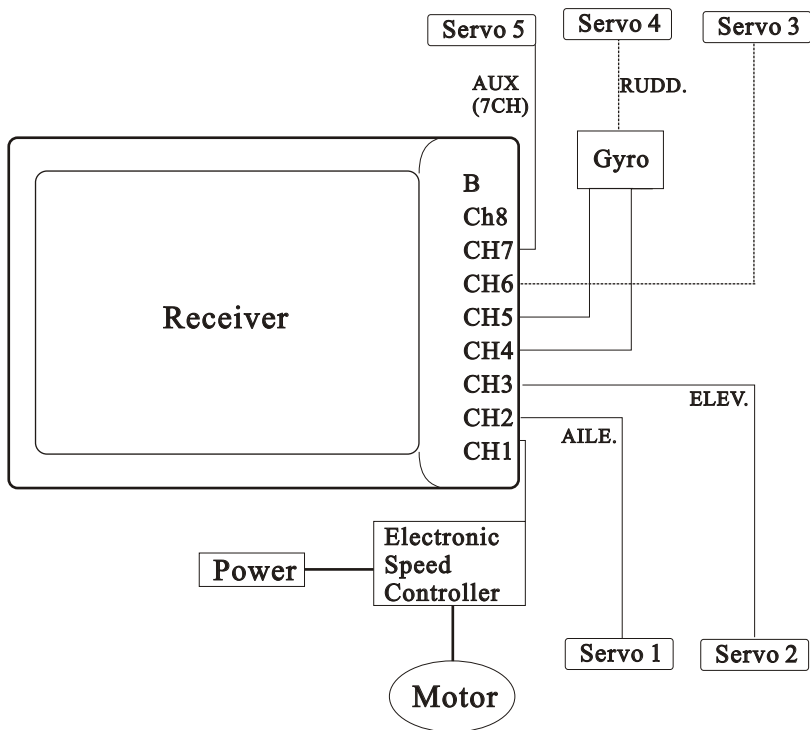
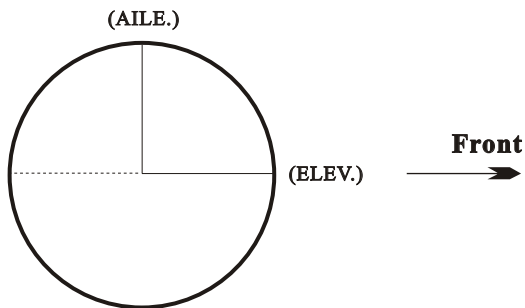

## 2.3 D/R

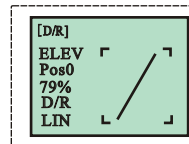

(2.3.1)

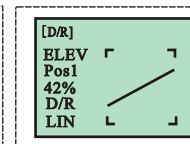

(2.3.2)

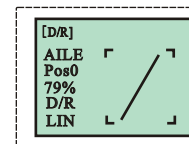

(2.3.3)

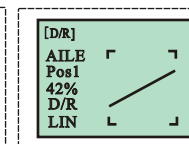

(2.3.4)



### Function

Dual rates are available for elevator and rudder channels of RC helicopters.



### Operation

- Press “●” to enter the menu – Roll “▲” or “▼”select the function (D/R ) in the list Press “●” to set the function and return to the previous menu.
- Roll “▲” or “▼” to select ELEV and AILE to set the data.
- ELEV setting ---- ‘ELEV’ is displayed  
Once the Elevator D/R switch is on/up, the data displayed is ‘Pos 0’. Use “◀” or “▶” to increase or decrease the data.(2.3.1)  
Once the Elevator D/R switch is off/down, the data displayed is ‘Pos 1’. Use “◀” or “▶” to increase or decrease the data.(2.3.2)
- AILE setting ---- ‘AILE’ is displayed  
Once the Aileron D/R switch is on/up, the data displayed is ‘Pos 0’. Use “◀” or “▶” to increase or decrease the data. (2.3.3)  
Once the Aileron D/R switch is off/down, the data displayed is ‘Pos 1’. Use “◀” or “▶” to increase or decrease the data. (2.3.4)
- Press “●” to save and return to the previous menu.

## 2.4 Rev. SW

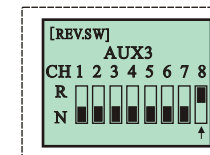
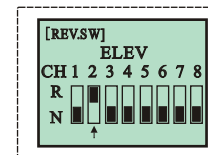
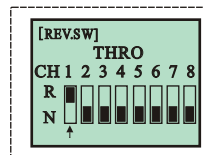

### Function

The Reverse switch is to change the servo for channel direction.





### Operation

- Select ‘REV. SW’ and enter the interface.
- Use “◀” or “▶” to select the channel arrow position. Press “▲” to reverse the channel; press “▼” to the normal status.
- Press “●” to save and return to the previous menu.

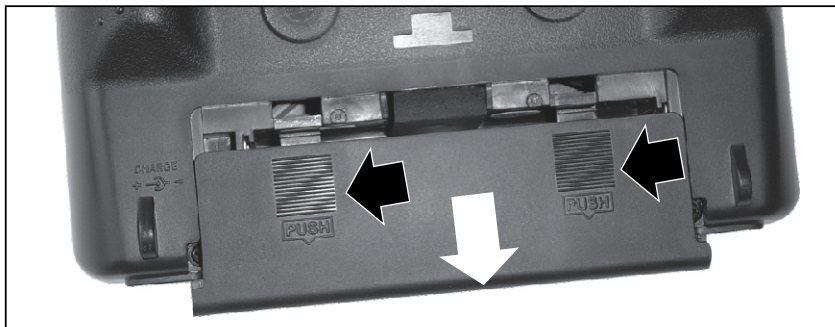
## 5.2 Loading Batteries



-  Open the battery cover in the direction of the arrow while pressing the non-slip cover grips.
-  Load the batteries in accordance with the battery holder polarity marking and close the battery cover.

### Swash Adjustment(For CCPM)

1. Turn on the transmitter. Press Select keys to enter the Swash Type and select swash type you want.
2. Open the horns of swash plate servos.
3. Move the throttle stick(engine turned on) to observe the circumvolving direction of the servos horn. By reverse, you can adjust the direction.
4. Press Select keys to enter the Sub Trim and return all values to zero.
5. Lock the servos' horns.
6. Observe the circumvolving direction of the swash plate by moving aileron and elevator. Change it by adjusting the value of aileron and elevator in Swash Mix list.
7. Gyro Adjustment-----Press Select keys to enter the Gyro Sensor and adjust the value you want by O/I switch.
8. Finished all of the above, you can fly your helicopter freely.

## 2.7 Hel-Plan Sel

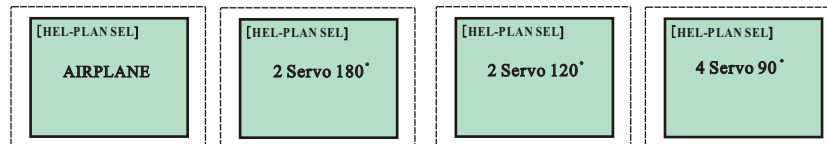

### Function

This function is to select a Swash type.



### Operation

1. Select 'HEL-PLAN SEL' and enter the interface.
2. Use "▲" or "▼" to select the mode: AIRPLANE/2Servos/3Servos/4Servos.
3. Press "●" to save and return to the previous menu.

## 2.8 Swash Mix



### Function

This function is to set the swash mixing data.



### Operation

1. Select 'SWASH MIX' and enter the interface.
2. Use "▲" or "▼" to select the channel arrow position. Press "◀" or "▶" to set the mixing data between the Travel value and the Throttle.
3. Press "●" to save and return to the previous menu.

**Notes: Please set the 'HEL-PLAN SEL' before entering the Swash Mix. (AIRPLANE; 2Servos;3Servos;4Servos;)**

## 4.1 Back of Transmitter



## 4.2 Trainer Function

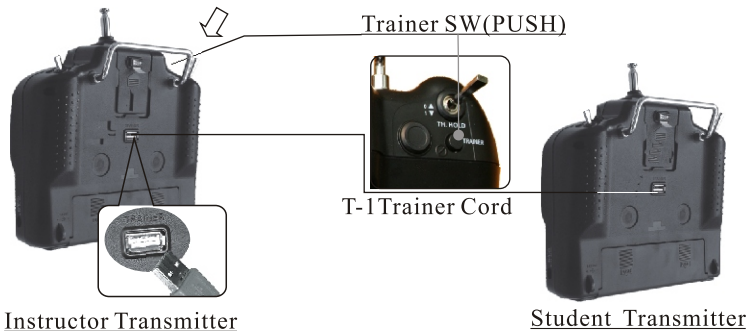

- Connect the student and the instructor transmitters with the trainer cord. Confirm the connection is OK.
  - The instructor transmitter is used as a normal setting; Turn down the student transmitter and take off its Replaceable Module and batteries. (Do not extend the antenna of student transmitter)
  - When the trainer switch of the instructor is pushed, like the following illustration, the model can be controlled by student. When the trainer switch of instructor returns, the model is under instructor's control.
  - The training function is only active with TR-1 trainer cord.
- WARNING : Plug only the original cables supplied by the factory!**

## 2.11 Pit Curv

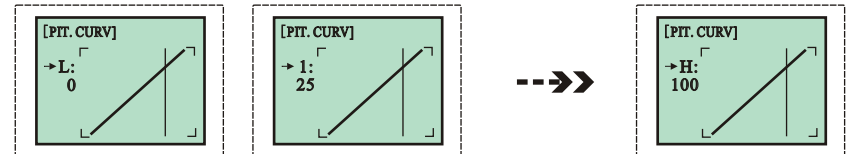

### Function

This radio offers 2 separate pitch curves with 5 adjustable points per curve: L/1/2/3/H.

### Operation

1. Select 'PIT. CURV' and enter the interface.
2. Use "▲" or "▼" to select any point at arrow that is in need to reset the data. Press "◀" or "▶" to set the data separately as the curve is being changed accordingly.
3. Press "●" to save and return to the previous menu.

## 2.12 MODELS

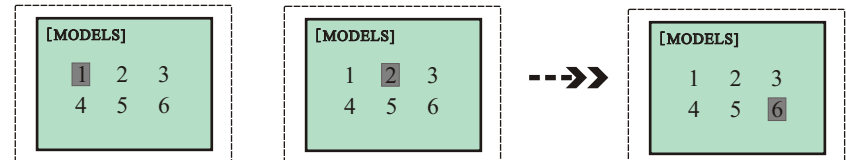

### Function

This radio has a memory for 6 models with their data individually.

### Operation

1. Select 'MODELS' and enter the interface.
2. Use "▲" or "▼" to select the model memorized with a code.
3. Press "●" to save and return to the previous menu.

## 5.2 Level Operation of Left Stick and Movement of Rudder

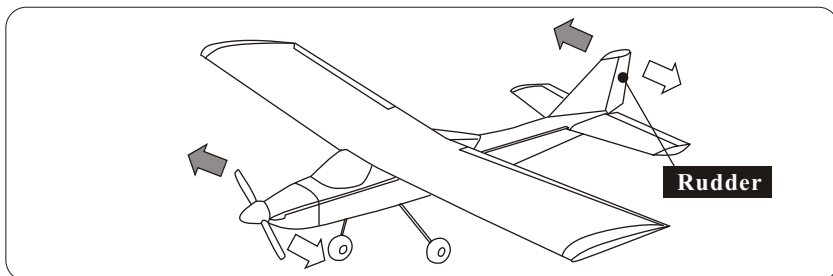

		Reverse: Normal Throttle: Right			
		M	Rudder		Plane
O					
L Stick Rightwards		R	→	R	→
L Stick Leftwards		L	←	L	←

Left Stick Horizontal Operation

## 5.3 Upright Operation of Right Stick and Movement of Throttle

		Reverse: Normal Throttle: Right			
		M	Motor	Plane	
O					
R Stick Downwards		Decelerating		Decelerating	
R Stick Upwards		Accelerating		Accelerating	

Right Stick Vertical Operation

## 2.15 Idle Thro

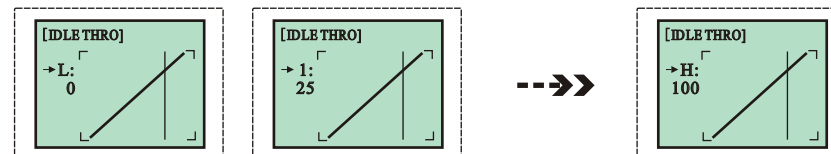

- Function**  
This function is a possibility to adjust the throttle curve with 5 points in 3D mode.
- Operation**
1. Select 'IDLE THRO' and enter the interface.
  2. Use "▲" or "▼" to select any point at arrow that is in need to reset the data. Press "◀" or "▶" to set the data separately as the curve is being changed accordingly.
  3. Press "●" to save and return to the previous menu.

## 2.16 Idle Pith

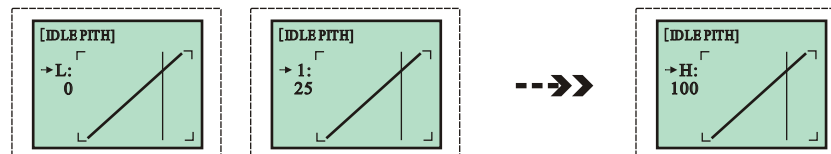

- Function**  
This function is a possibility to adjust the pitch curve with 5 points in 3D mode.
- Operation**
1. Select 'IDLE PITH' and enter the interface.
  2. Use "▲" or "▼" to select any point at arrow that is in need to reset the data. Press "◀" or "▶" to set the data separately as the curve is being changed accordingly.
  3. Press "●" to save and return to the previous menu.

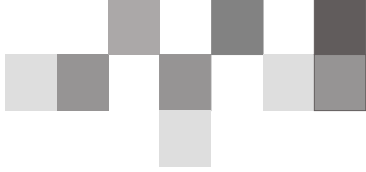
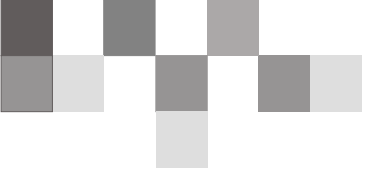

## Caution

- ✎ To work your R/C with your models correctly and safely, read this manual carefully and keep it in a safe way as a reference introduction in the future.
- ✎ Warning:
  1. This product is only equipped for radio controlled models;
  2. The usage of this product should be approved by local relevant law or regulations;
  3. We will be not responsible for the damages caused by unauthorized modification, adjustment or replacement of parts of this product;
  4. The manual may be altered without prior notice. Please contact us if you have any corrections or clarifications that should be made in the manual.
- ✎ Please pay more attention on the parts in this manual, which marked with “warning”.
- ✎ Because of disturbance, do not work your radio control system simultaneously with others at the same frequency.
- ✎ Before starting the transmitter, make sure the transmitter batteries are well loaded .The voltage of transmitter batteries never be lower than 8.6V. And please check and confirm that the servos are all well and properly connected.
- ✎ Please take off batteries from transmitter after flying and during the transportation.
- ✎ Please check and have a test on control surfaces to confirm the transmitter handling of each part prior to each takeoff. The frequencies of the module and the receiver should be the same.
- ✎ The instructor and the student transmitters must accord with each other when using trainer function.
- ✎ Keep the radio system away from moist, high temperature and strong shake. Do not clean the product with solvent.
- ✎ Do not fly your models near airfield, schools, hospitals, residences, power transmission network, communication facilities and other places that are forbidden for starting the transmitter. Please stop flying your models with the radio on rainy or windy days, or at night.
- ✎ Do not fly the models when you are tired, sick , intoxicated, or not in good spirit.
- ✎ The antenna do not touch anything else when power switch is turned on. Do not leave this product and its accessories within the reach of small children.
- ✎ Please use this product according to your local relevant law or regulation, we are not responsible for any incidents or damages.
- ✎ **Important Comments: All USB ports in this transmitter are just used for our special cord with its USB structure and without USB agreement. DO NOT USE your USB cables with transmitter.**

### WARNING :IDLE ON

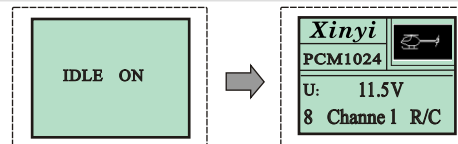
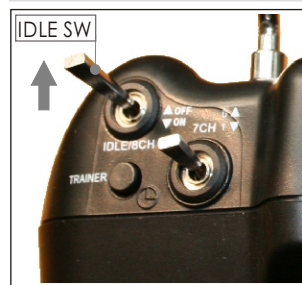

✎ If you happen to turn on the power switch and the LCD is display "IDLE ON "with alarming; Please turned the "IDLE" switch to 'OFF', and TX action will display normally.

### WARNING :TH. HOLD ON

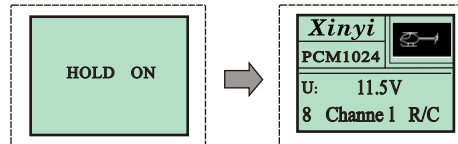
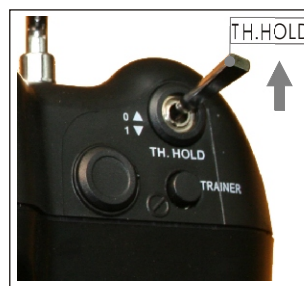

✎ If you happen to turn on the power switch and the LCD is display " HOLD ON "with alarming; Please turned the "TH. HOLD" switch to "0", and TX action will display normally.

### 2.4G Radio Data Transmission

1. Technology of DSSS (Direct Sequence Spread Spectrum) 2.4G radio transmission and receiving
2. Working frequency is the worldwide universal frequency band of ISM ( Industrial Scientific and Medical), free of charge, and the range is from **2.400 GHz to 2.483 GHz**.
3. Max transmitting power: **20dBm 200mA**.
4. Max. receiving sensitivity: **-93dBm**.
5. Working current at transmitting end: **200mA and 300mA**.
6. Working current at receiving end: **< 50mA**.
7. Data transfer rate : **19200 bit/Sec**.
8. Data stable transmission distance: **300 M**.

#### Remark:

**Please pucker 2.4G radio antenna to 90° when you flying, and the receiver signal will be perfect.**

## 2.1 Menu

LOGO	<b>Xinyi</b>	Model Type
Modulation Type (PCM or PPM)	PCM1024	
Channel Type	U: 11.5V	Voltage
	8 Channel R/C	

- It is a default setting of helicopter in Model Type initially.
- When the voltage displayed is lower than 8.6V below, the number will flash with warning.

## 2.2 Function List

"[FUNC.LIST]"	
" D/R "	Dual Rates
" REV. SW "	<b>Reversing Switch</b>
" SUB Trim "	Sub Trim
" TRVL ADJ. "	Travel Adjustment
" HEL-PLAN SEL "	Heli.&Plane select
" SWASH MIX "	Swash Mixing
" STICK MODE "	Stick Mode
" THRO CURV "	Throttle Curve
" PIT CURV "	PIT. Curve
" MODELS "	Models
" CLEAR "	Clear
" GYRO SENS "	Gyro Sensitivity
" IDLE THRO "	Idle Throttle
" IDLE PITH "	Idle Pitch
"SET CHANNEL"	2.4 channel select
"STICK ADJ"	STICK ADJ
"THRO HOLD"	Thro. hold
" Exit "	Exit

## 6.3 Four-servo Connection Diagram

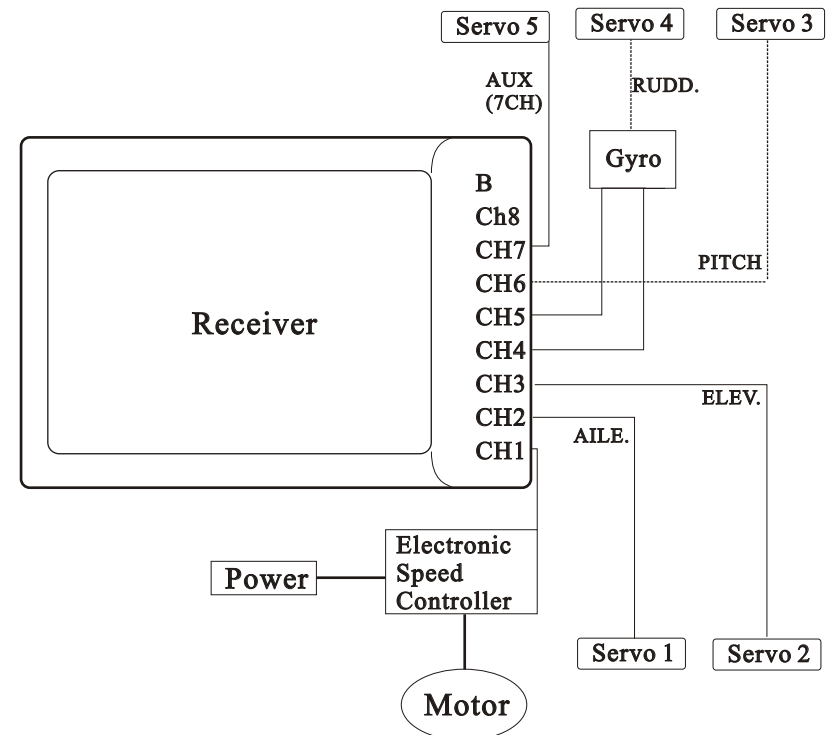
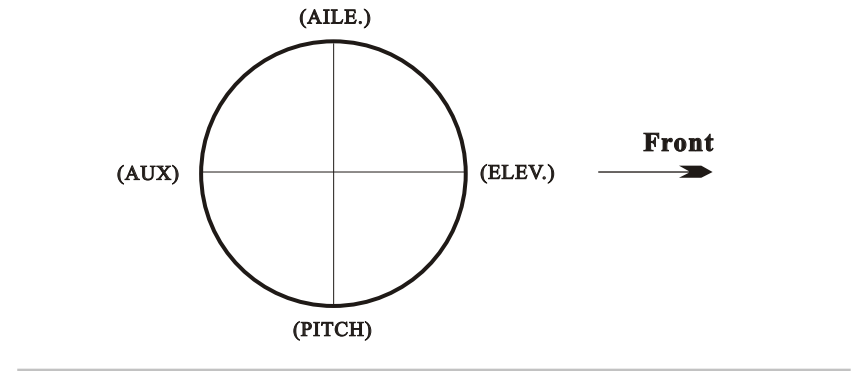

## 2.5 Sub Trim

[Sub.Trim]	
THRO	ELEV
→-13%	-19%
AILE	RUDD
-20%	+10%

(2.5.1)

[Sub.Trim]	
GEAR	FLAP
→-18%	+ 8%
PITH	AUX3
- 3%	+10%

(2.5.2)

### Function

The Sub trim is a trim position for setting on 8 channels.

### Operation

1. Select 'Sub Trim' and enter the interface.
2. Use "▲" or "▼" to select the channel arrow position. Press "◀" or "▶" to change the data.(2.5.1)
3. Use "▲" or "▼" to display circularly the other 4 channels below. Press "◀" or "▶" to change the data. (2.5.2)
4. Press "●" to save and return to the previous menu.

## 2.6 Trvl ADJ.

[TRVLADJ]	
THRO	ELEV
→-13%	-19%
AILE	RUDD
-20%	+10%

(2.6.1)

[TRVLADJ]	
GEAR	FLAP
→-18%	+ 8%
PITH	AUX3
- 3%	+10%

(2.6.2)

### Function

The function is an electronic means to adjust the servo travel value.

### Operation

1. Select 'TRVL ADJ.' and enter the interface.
2. Use "▲" or "▼" to select the channel arrow position. Press "◀" or "▶" to change the data.(2.6.1)
3. Use "▲" or "▼" to display circularly the other channels below. Press "◀" or "▶" to change the data. (2.6.2)
4. Press "●" to save and return to the previous menu.

## 6.1 Three-servo Connection Diagram

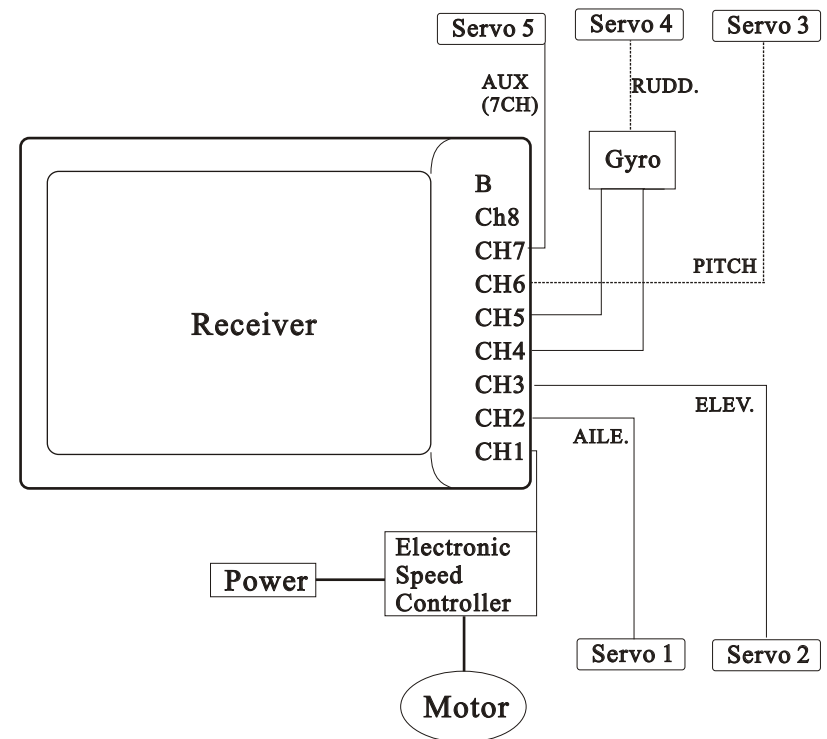
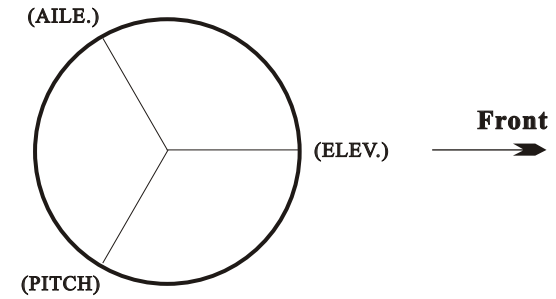

## 5. Installation and Adjustment

This chapter will introduce the installation and adjustment of some important parts of transmitter, including Control Stick Length and Tension Adjustment, Loading Batteries, Loading Module and Connection between Receiver and Servos.

### 2.9 Stick Mode

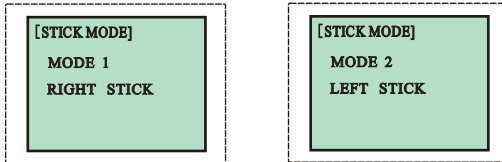

#### Function

This function allows you to exchange mode 1 and mode 2.

#### Operation

1. Select 'STICK MODE' and enter the interface.
2. Use "▲" or "▼" to select the mode.
3. Press "●" to save and return to the previous menu.

**Notes:** To change the mode, it is necessary to remove the model of the transmitter.

### 2.10 Thro Curv

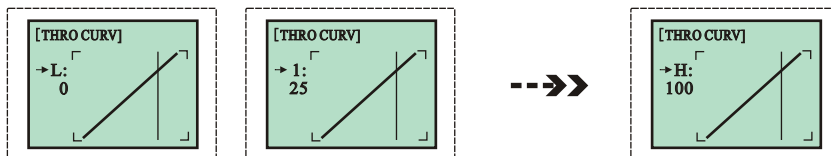

#### Function

This radio offers 2 separate throttle curves with 5 adjustable points per curve: L/1/2/3/H.

#### Operation

1. Select 'THRO CURV' and enter the interface.
2. Use "▲" or "▼" to select any point at arrow that is in need to reset the data. Press "◀" or "▶" to set the data separately as the curve is being changed accordingly.
3. Press "●" to save and return to the previous menu.

### 5.1 Control Stick Length&Tension Adjustment

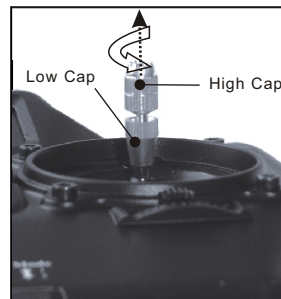

For your convenient operation, the stick length can be adjusted as your demand.

Screw the high cap anticlockwise to the desired length and then, screw the low cap anticlockwise to lock the high cap as the left illustration.

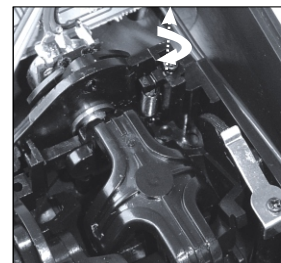

For your convenient operation, the stick tension can be adjusted as your demand.

Use the screwdriver to adjust the screw clockwise for the desired tension. anticlockwise to loosen stick feel, clockwise to tighten stick feel.

This adjustment need take off the back cover of transmitter.

## 2.13 Clear

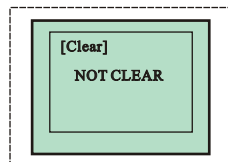

(2.13.1)

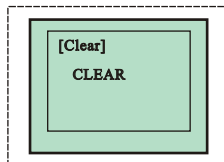

(2.13.2)

### Function

This function helps with returning the factory preset.

### Operation

1. Select 'CLEAR' and enter the interface.  
[NOT CLEAR] and [CLEAR] are displayed.  
[CLEAR] is to return the factory preset; (2.13.1)  
[NOT CLEAR] is not to return the factory preset. (2.13.2)
2. Use "▲" or "▼" to select the answer.
3. Press "●" to save and return to the previous menu.

## 2.14 Gyro Sens

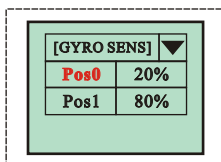

(2.14.1)

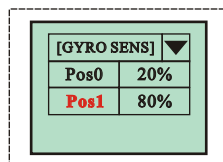

(2.14.2)

### Function

This function offers a gyro adjustment with 2 points.

### Operation

1. Select 'GYRO SENS' and enter the interface.
2. Once 'the Gyro Sensitivity Adjustment SW' is off/down, the data displayed is 'Pos 0'.  
Use "◀" or "▶" to adjust the data.
3. Once 'the Gyro Sensitivity Adjustment SW' is on/up, the data displayed is 'Pos 1'. Use "◀" or "▶" to adjust the data.
3. Press "●" to save and return to the previous menu.

## 5.4 Level Operation of Right Stick and Movement of Aileron

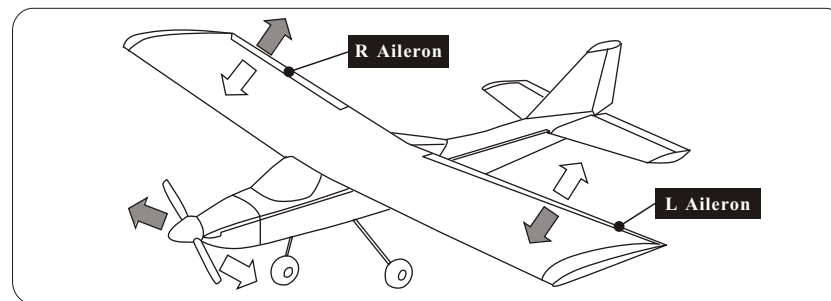

		Reverse: Normal Throttle: Right					
M O		Left Aileron		Right Aileron		Plane	
	R Stick Rightwards	D	↓	U	↑	R	→
R Stick Leftwards	U	↑	D	↓	L	←	

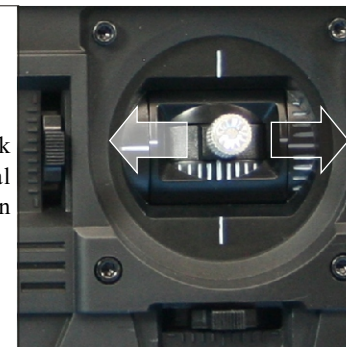

## 2.17 SET CHANNEL(Only for 2.4G RC)

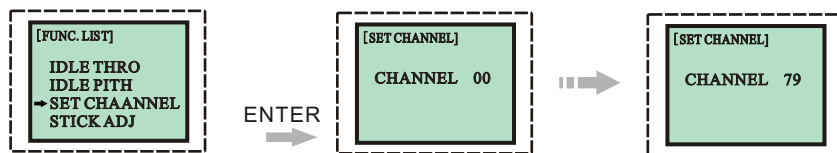

### Function (For 2.4 RC)

There are 0-79 signal channels which related to different frequency options in transmitter.

### Operation

- 1.Select 'SET CHANNEL' and enter the interface.
- 2.Use "◀" or "▶" to select the channel .
- 3.Press "●" to save and return to the previous menu.

**NOTE:** Once alter the channel, take the receiver close to the transmitter and restarted (Battery reloaded), then receiver will search for relevant channel automatically. (LED light flashes when searching, LED light on means searched successfully.)

## 2.18 STICK ADJ

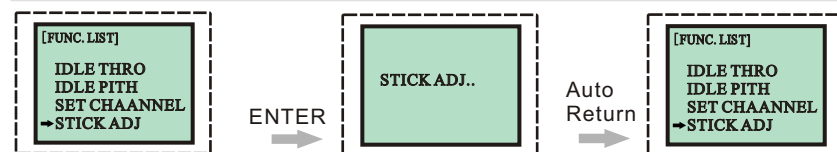

### Function

Stick neutral position setting

### Operation

- 1.Select 'STICK ADJ' and Press "●" to set Stick neutral position.
- 2."STICK ADJ.." show on display means adjusting, when"STICK ADJ.."disappear and back to "FUC.LIST" means adjusted successfully.

**NOTE:** Before your operation, please be sure that the 4 proportional channels of the sticks are in the neutral position, and the 4 electronic trim buttons are also in the neutral position.

## 2.19 THRO HOLD

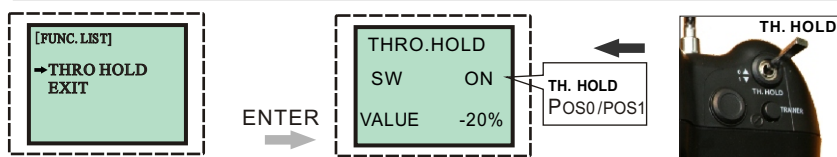

### Operation

- 1.Select 'THRO HOLD' and enter the interface.
- 2.Set the "TH HOLD" switch at the top of the transmitter:  
When "TH HOLD" is in '0' position, LCD shows SW "OFF", and now you can not set the value in OFF position .  
When "TH HOLD" is in '1' position, LCD shows SW"ON", and now you can set the value in ON 1 position by "◀" or "▶";(+50~-20)
- 3.Press "●" to save and return to the previous menu.

## 3.1 Upright Operation of Left Stick and Movement of Elevator

This chapter will introduce transmitter's stick operation and movement of each servo of Airplane, including stick operation and movements of Elevator, Rudder, Throttle, Aileron. (Mode 1)(Right Throttle)

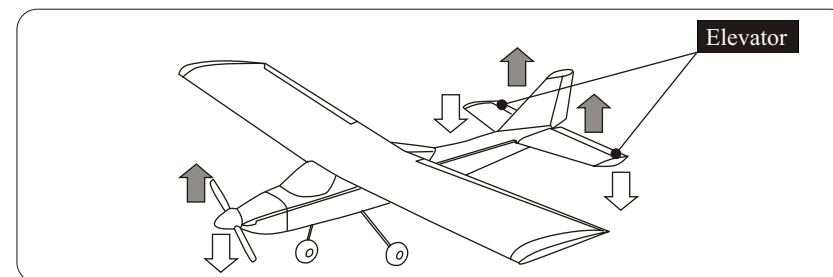

		Reverse: Normal Throttle: Right			
		M	Elevator		Plane
Left Stick Vertical Operation	O				
	L Stick Downwards	U	↑	U	↑
	L Stick Upwards	D	↓	D	↓

